

All questions are for both separate science and combined science students

- 1 The photograph shows a water barrel with a tap.  
The barrel is used to store rainwater.



A student investigates the water depth in the barrel.  
She measures the depth and then opens the tap.  
As water flows out of the barrel, she measures the depth every minute.  
The table shows her results.

Time in minutes	Depth in cm
0	86
1	52
2	31
3	18
4	11
5	7
6	4

(a) Which two measuring instruments should the student use in her investigation?

(2)

- 1 .....
- 2 .....

(b) (i) Plot a graph to show how the depth changes with time, and draw the curve of best fit.

(5)

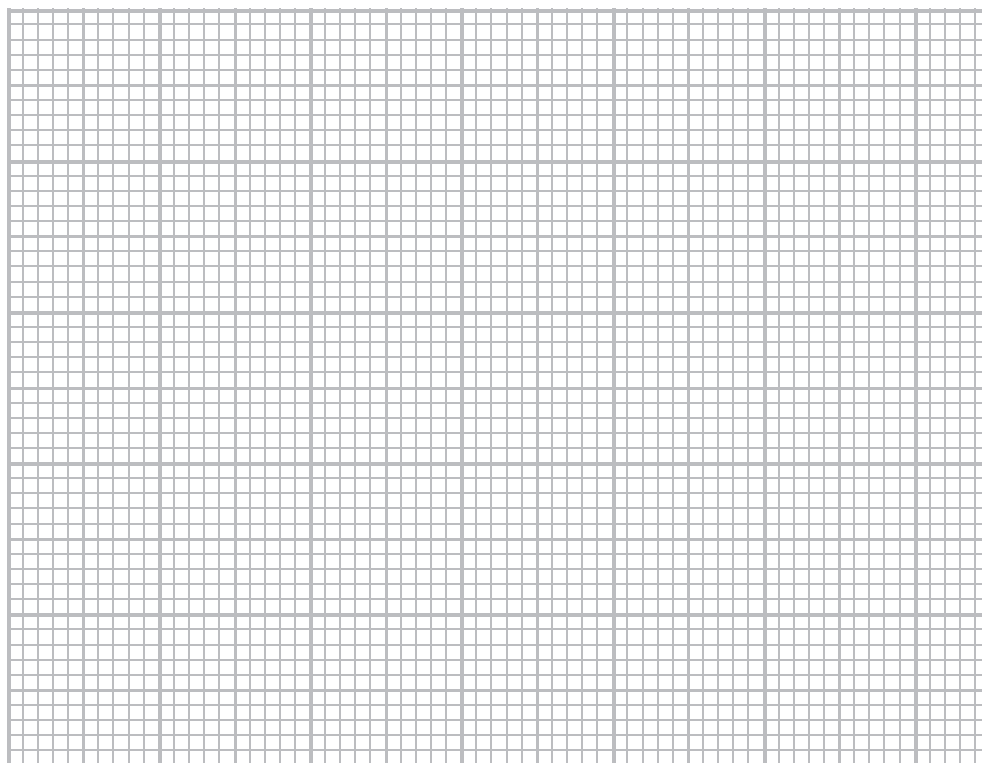

(ii) Describe the relationship between depth and time.

(2)

.....

.....

.....

.....

(c) The student notices that the water flows out less quickly as time passes.

Suggest a reason for the decrease in flow.

(1)

.....

.....

.....

**(Total for Question 1 = 10 marks)**

2 This question is about temperature and pressure in gases.

(a) A gas is heated in a container which has a constant volume.

The particles in the gas

(1)

- A expand
- B hit the walls of the container harder
- C move closer together
- D have a lower average speed

(b) Describe what happens to the average kinetic energy of particles as the temperature decreases from 10K towards 0K.

(2)

.....

.....

.....

.....

(c) (i) Convert a temperature of 27 °C into kelvin (K).

(1)

temperature = ..... K

(ii) The gas in a cylinder has a pressure of 210 kPa at a temperature of 27°C.

Calculate the new pressure when the temperature of the gas rises to 81°C.

(3)

pressure = ..... kPa

**(Total for Question 2 = 7 marks)**

- 3 A student measures the diameter of a coin.  
She uses the digital caliper shown in the photograph.



The digital caliper gives readings to the nearest 0.01 mm.

- (a) The student measures the diameter of the coin eight times.

Her readings are shown below.



- (i) Circle the anomalous reading. (1)
- (ii) Calculate the average diameter of the coin. (3)

Average = ..... mm

(b) The student wants to find the thickness of a coin.

She takes several similar coins and measures them together as shown.



She says:



If I measure all the coins at once and divide this value by the number of coins it will be more accurate.

Do you agree with the student?

Explain why.

(2)

.....

.....

.....

.....

.....

(c) The student wants to find the density of the coin.

She uses her values for the diameter and thickness of the coin to calculate its volume.

What else must she do to find the density of the coin?

(3)

.....

.....

.....

.....

.....

.....

.....

.....

.....

.....

.....

.....

.....

.....

.....

.....

.....

.....

.....

.....

.....

.....

.....

---

**(Total for Question 3 = 9 marks)**

4 The photograph shows some large concrete cubes.



The mass of one of the concrete cubes is 1000 kg.

(a) State the weight of this concrete cube.

Give the unit.

(2)

weight of concrete cube = ..... unit .....

(b) The density of this concrete cube is  $2300 \text{ kg/m}^3$ .

(i) State the equation linking density, mass and volume.

(1)

(ii) Calculate the volume of this concrete cube.

(2)

volume of concrete cube = .....  $\text{m}^3$

(c) The graph shows the volumes of 1000 kg of some other materials.

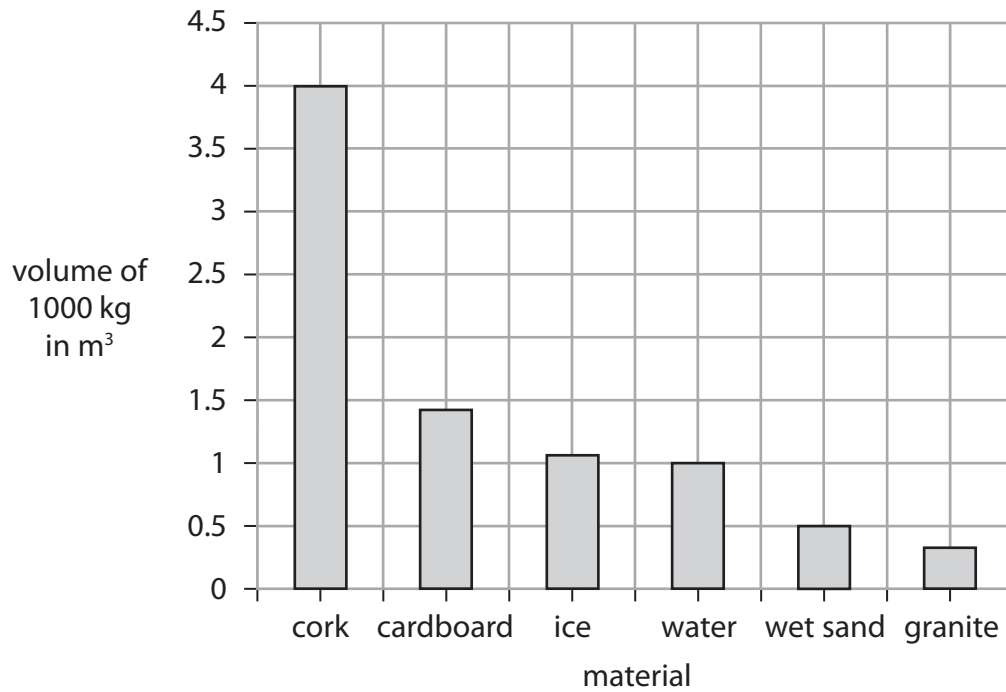

(i) State the type of graph shown.

(1)

(ii) Give a reason why a line graph is not an appropriate way to display this data.

(1)

(iii) Use information from the graph to compare the densities of cork and water.

(2)

**(Total for Question 4 = 9 marks)**



5 (a) The diagram shows the fuel used in some nuclear reactors.

The fuel is contained inside spheres.

The silicon carbide layer of each sphere is designed to contain the fission products for at least one million years.

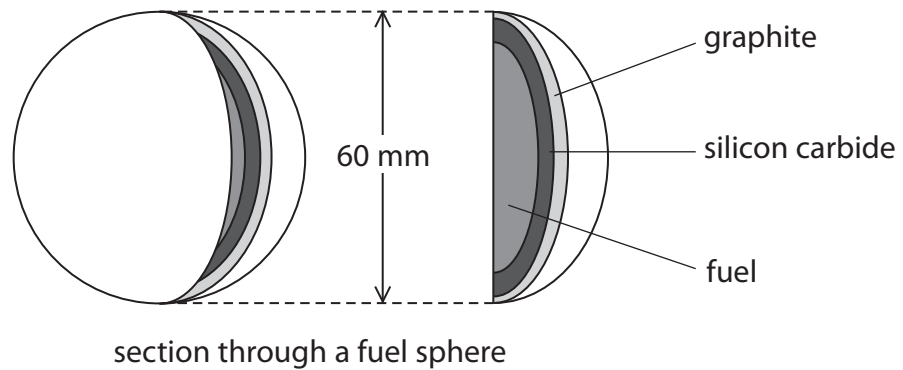

(i) Give the name of a fuel that could be used.

(1)

.....

(ii) Explain what is meant by the term **fission products**.

(2)

.....

.....

.....

.....

(iii) Explain why it is important to contain these fission products for such a long time.

(2)

.....

.....

.....

.....

(iv) The graphite layer in every fuel sphere acts as a moderator.

What is the function of the moderator in a nuclear reactor?

(1)

.....

.....

(v) The nuclear reactor also contains boron control rods.

Explain why it is dangerous to remove most of the control rods from the reactor.

(2)

.....

.....

.....

.....

(b) The reactor is cooled with helium gas.

The gas enters the reactor at 500 °C.

(i) What is this temperature in kelvin?

(1)

temperature = ..... K

(ii) Helium gas enters the reactor at a pressure of 8.40 MPa and leaves the reactor at a temperature of 1170 K.

Calculate the pressure of the helium gas as it leaves the reactor.  
[assume the volume of the gas does not change]

(3)

pressure = ..... MPa

**(Total for Question 5 = 12 marks)**